

# Unfinished Solid Flooring

<b>PRODUCT DATA SHEET</b> <b>MADERACRE TIMBER</b>	<b>Code:</b>	
	<b>Version:</b>	4
	<b>Date:</b>	19/10/2020

<b>PRODUCT</b>	<b>UNFINISHED SOLID FLOORING</b>
----------------	----------------------------------

### Fingerjoint Assembly

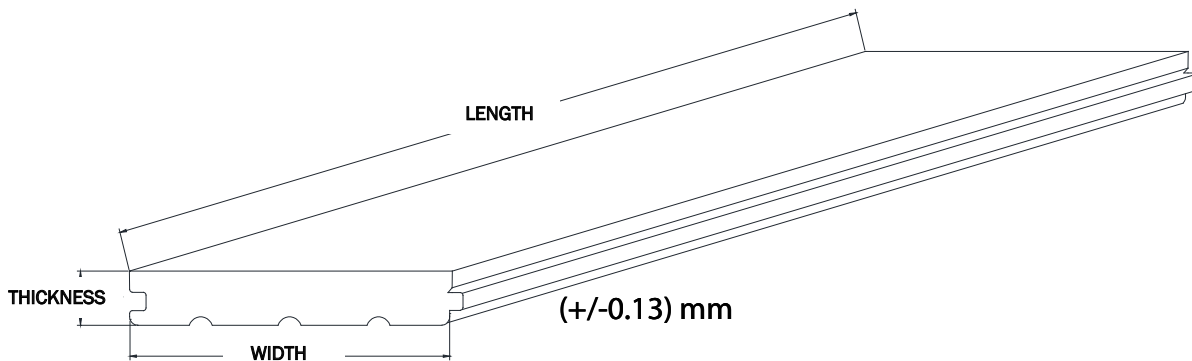

DIMENSIONS								
INVOICE SIZES			REAL SIZES			TOLERANCE		
Thickness	Width	Length	Thickness	Width	Length	Thickness	Width	Length
19	82.5	300mm to 1800mm	19	82.5	300mm to 1800mm Nominal 2100mm	(+/- 0.17)	(+/-0.13) mm	300mm to 1800mm (Over sizes or tolerances depend on the customer!)
	101	300mm to 1800mm		(+/-0.17) mm				
	126	300mm to 1800mm		(+/-0.17) mm				
	140	300mm to 1800mm		(+/-0.2) mm				

<b>NOTE</b>	In B Quality up to 250 mm length is accepted in all widths.
-------------	---

<b>PROFILE</b>	T&G-4S-MB4 / SE
----------------	-----------------

### T&G-4S-MB4 (Microbeveling)

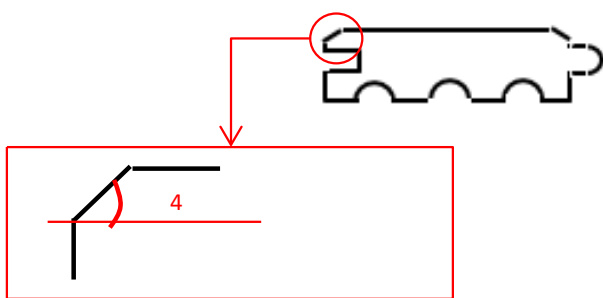



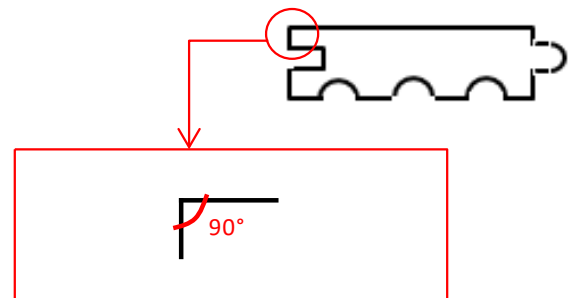

### T&G-4S-SE (Squaring)



Up to 1/3 shortfall for A Quality and up to 1/2 shortfall for B Quality is accepted, along the piece, on the heads and edges. Small scratches perceptible to light and burn marks, produced by the heads of the moulding machine, are accepted on the face. Very small scratches along the piece and roller and crevice marks in the middle of the piece only on the back. Stained faces due to external agents (grease, oil, etc.) are not accepted.

<b>MOISTURE CONTENT:</b>	'KD (6% - 10%) Moisture content may change according to customer's requirement
--------------------------	--

SHAPE				
Twisting	Bowing	Bending	Cupping	Squareness
				Up to 0.04 mm of clearance per 25 mm in width is allowed in the socket of cross-cut heads.
As long as it is corrected with minimum pressure.	As long as it is corrected with minimal pressure	As long as it is corrected with minimal pressure	Not Accepted	

<b>QUALITY</b>	A (no sapwood, bites, dead knot, cracks and crevices in the face) B (some sapwood, some bites)
----------------	---